

# 3D積層智造實務：數位光學式3D列印

-3D列印技術介紹

-3D列印設備系統性能

-3D列印技術應用與發展趨勢

Roger Chen

陳昭舜

2020.Aug

**MICRAFT**  
Digi-optical 3D printer

## 個人簡歷



### 學歷：

- 1988/09-1992/06 (學士) 台灣大學、機械工程系
- 1992/09-1994/06 (碩士) 台灣大學、機械工程研究所

### 經歷：

- 2004 - Present : 揚明光學經理, 處長, 協理
- 2007 June : 國際顯示學會 (SID, Society of Information Display) Projection Sub-Committee Member
- 2016 June : 經濟部工業局 "3D列印工程師能力鑑定委員會" 專業委員
- 2017 Nov : 三維列印協會 第二屆 常務理事
- 2019 April : 三維列印協會 第三屆 理事長
- 2019 April : 經濟部標準檢驗局 3D列印(積層製造)相關標準的先期審查會委員

### 專長 & 產品開發：

- 光學設計, 機構設計, 光機電熱, 模組開發, 系統整合. 至2020累積多國約40篇專利.
- 產品開發經歷 : Scanner, Digital Still Camera, Projector, Projection Display, 3D printer, ..
- 現職為揚明光學 新事業開發事業部 協理, 負責 3D Printer 事業: BU head.

# 光固化(VP) - 數位光學式 DLP 3D Printer

- 序論與常見光固化技術的比較
- 3D 列印 UV DLP 光學原理與性能
- 數位光學DLP 3D列印機設計
- 數位光學 3D列印機的應用
- 未來展望

序論與常見光固化技術的比較

# 序論

積層製造屬於加法製程, 相較於傳統製程具有下列優點:

- 僅需機台建置成本, 不需要模具單位成本不隨數量而變化 適合少量多樣
- 適合客製化複雜性高的設計
- 技術多元材料多樣 應用廣泛

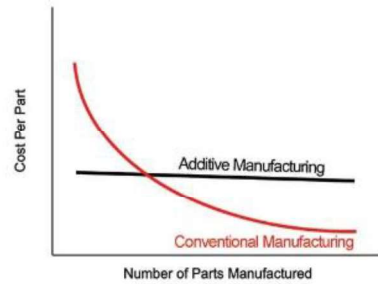
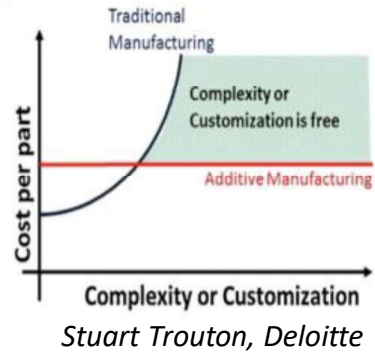
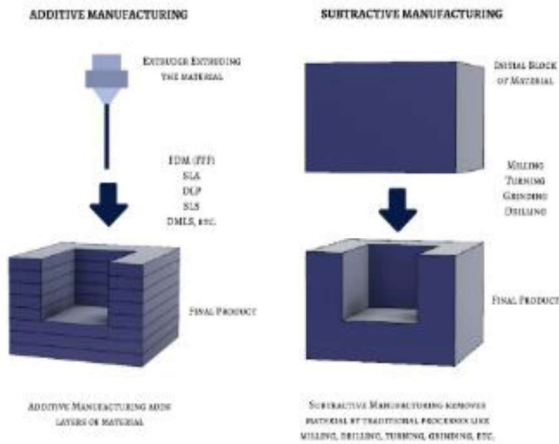

## 3D Printer Global Market Overview

### Global Market Scale

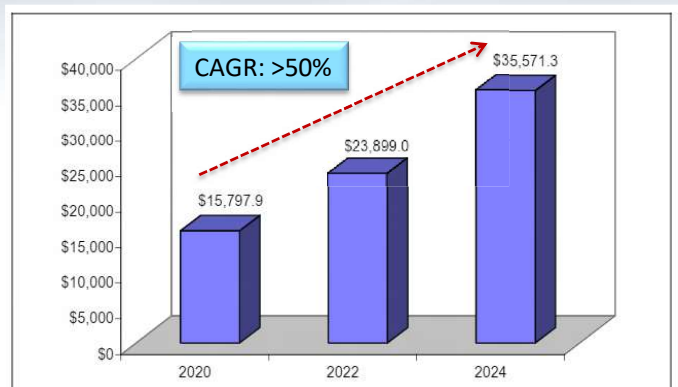
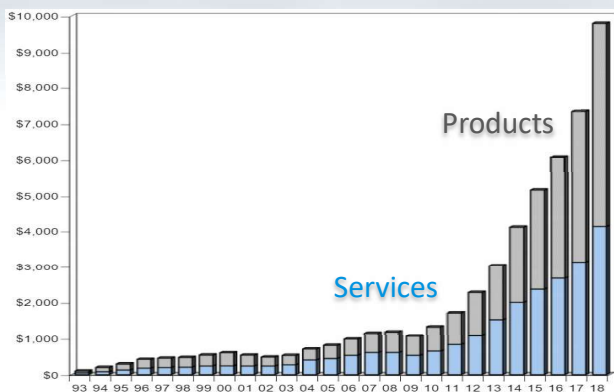

Wohlers Report 2019.  
Revenue in Million USD

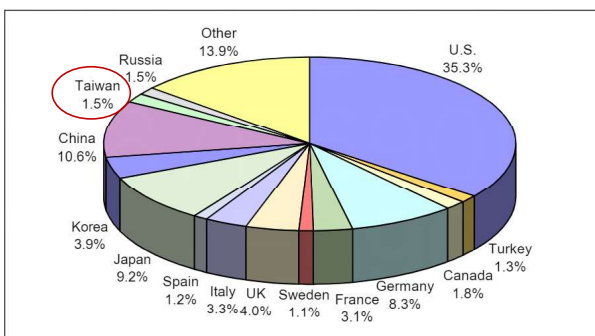

- By 2024, is projected to generate over \$35 billion per year!
- "Global trend "predicts 50% of manufactured goods will be printed in 2060!

# What 3D Printers Serve : Industries and Applications

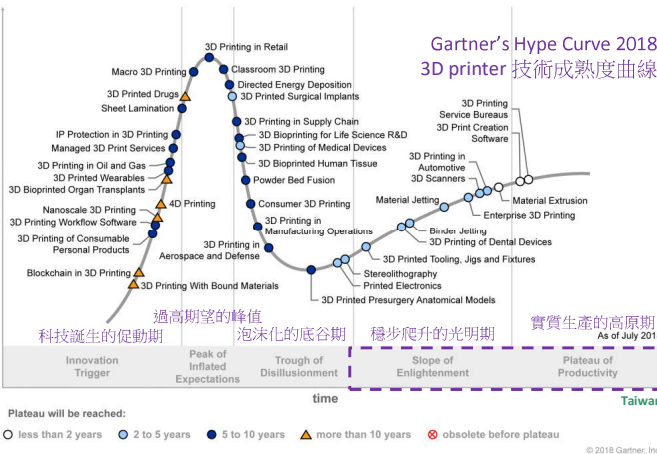
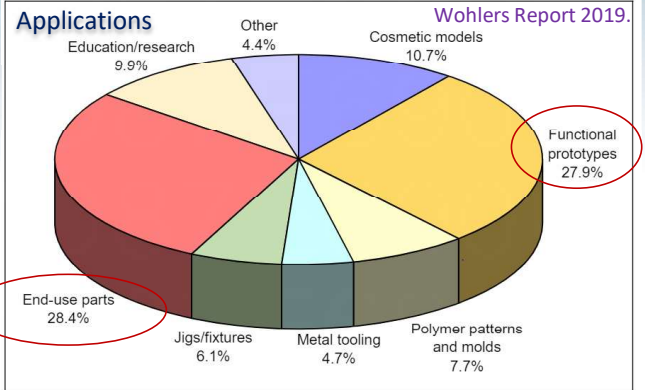
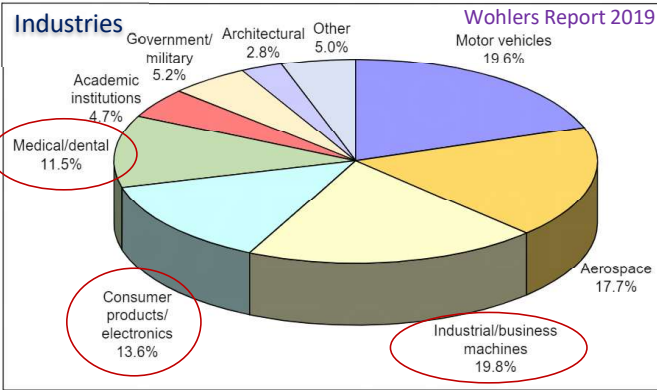

- 3D Printing 從消費性電子朝醫療及工業應用領域，列印品從觀看用模型朝終端產品零件，功能件發展。

- Predictions per Gartner's Hype Curve :

- Medical : By 2023, **25%** of medical devices in developed markets will make use of 3D printing
- Metal : By 2020, 3D printed metals and alloys will become a critical element in supply chains for replacement parts in commercial, military and even some consumer markets.

## 3D Printer 產業鏈

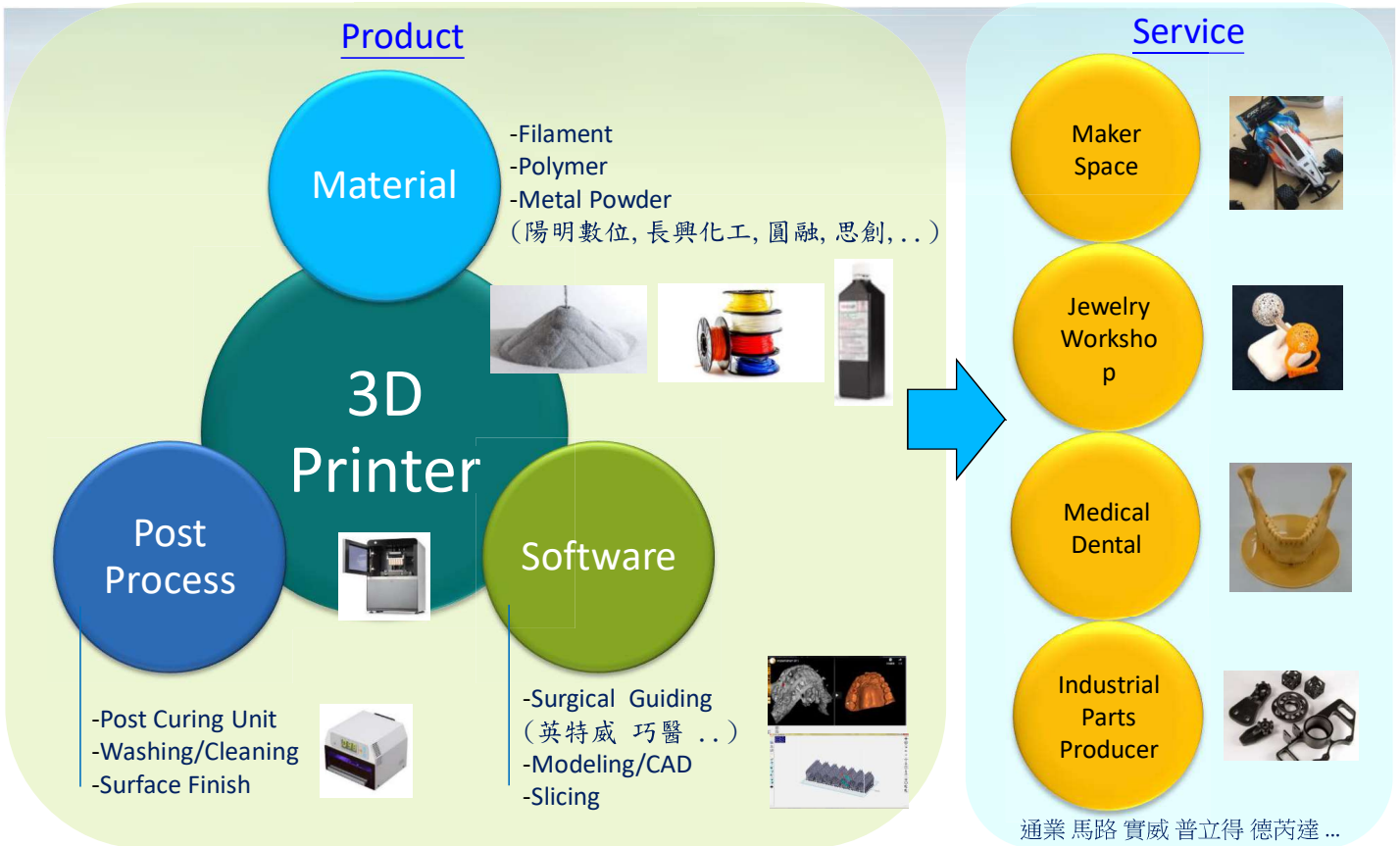

# 3D Printer 技術分類

光固化成型  
Vat Photopolymerization (SLA, DLP, LCD, ...)

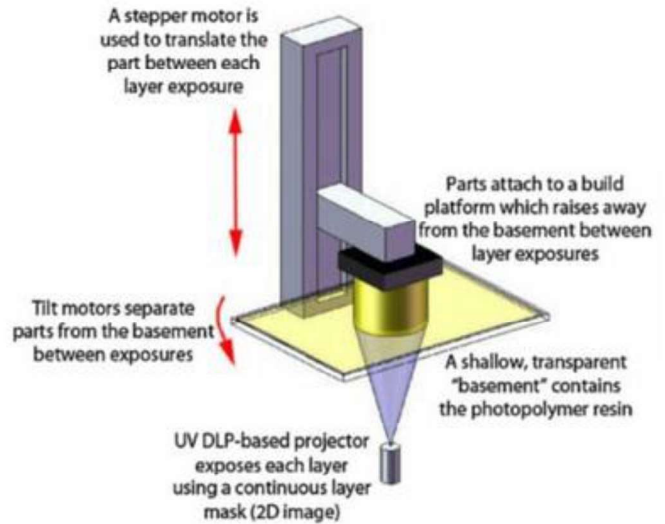
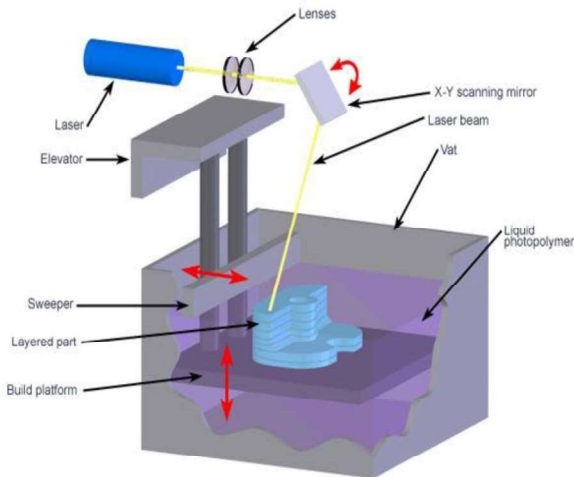
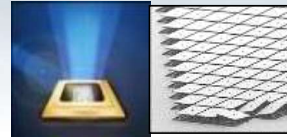

# 3D Printer 技術分類

材料擠出成型  
Material Extrusion (FDM)

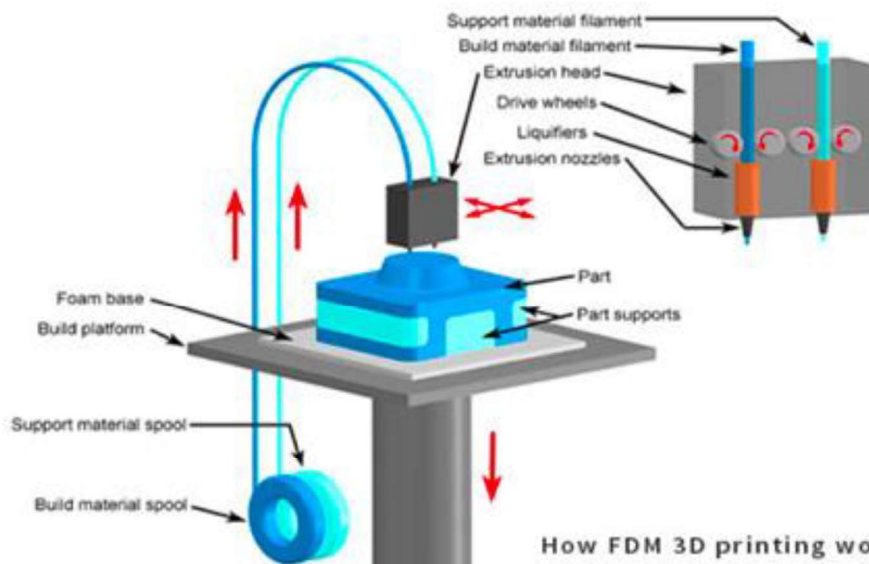

How FDM 3D printing works

# 3D Printer 技術分類

黏著劑噴印成型  
Binder Jetting

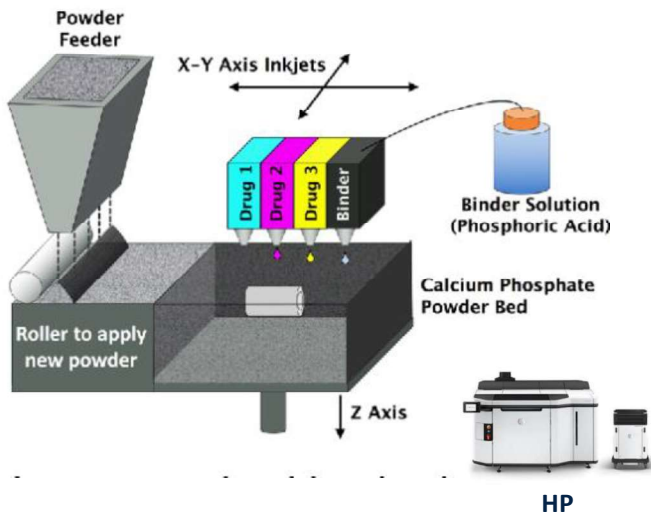

粉床熔化成型  
Powder Bed Fusion (SLS, SLM)

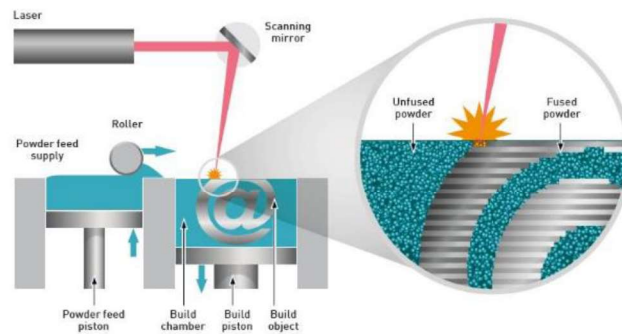

# 3D Printer 技術分類

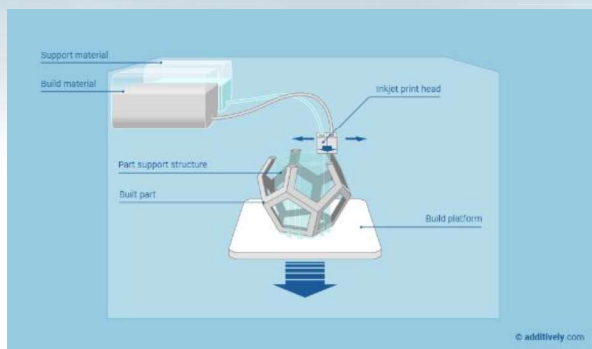

材料噴印成型  
Material Jetting

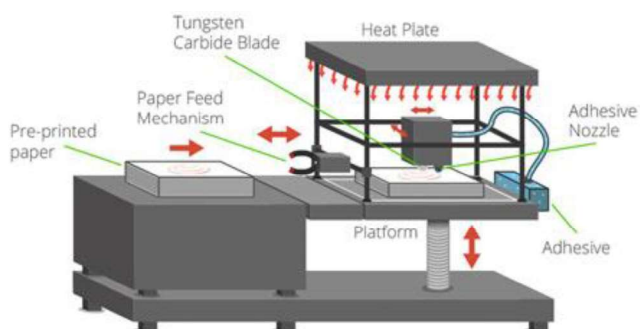

薄片疊層成型  
Sheet Lamination

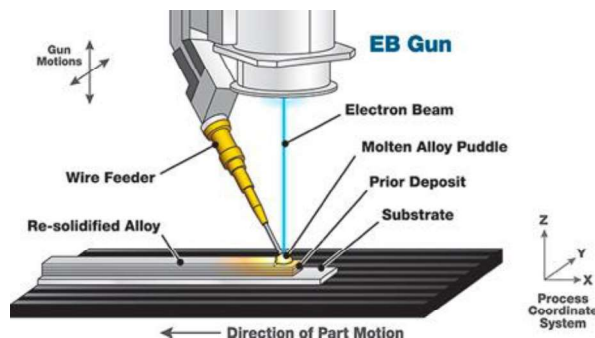

指向性能量沉積成型  
Directed Energy Deposition

# 塑膠類型的3D列印機台市場分布

## 光聚合固化技術 (VP) :

- 積層製成品材料多元性最廣,支撐結構材料與工件材料相同。
- 商品化的3D列印機市場涵蓋範圍從消費型產品到工業等級設備。
- 具最佳的準確度及優異之表面光滑度。



# 常見的光固化(VP) 3D列印技術

## 光聚合固化3D列印(VP, Vat Photopolymerization) :

- 藉由光激發聚合作用,在成形面上選擇性地將槽內待成形的液態或漿態光聚合物固化或預固化,配合控制升降平台一層層堆疊成型為三維實體的一種積層製造(AM, Additive Manufacturing)技術。

### 依光源或光調變方式主要分為

- DLP 數位光學(Digital Light Processing) - 面光源曝光
- Laser雷射 (SLA, Stereo Lithography Appearance) - 點光源曝光
- LCD液晶(Liquid Crystal Display) - 面光源曝光

### 成形方式

- 上拉式(bottom Up)
- 下沉式(Top Down)

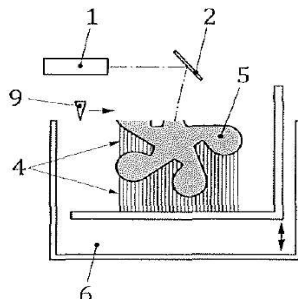

(a) 使用點光源之光聚合固化

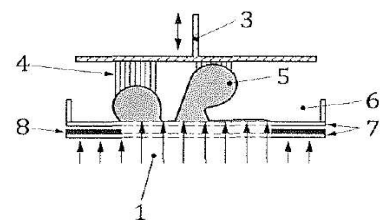

(b) 使用面光源之光聚合固化

### 說明

- |             |                |
|-------------|----------------|
| 1 能量光源      | 6 裝有液態光固化樹脂的槽體 |
| 2 傾斜的聚焦鏡面   | 7 透明平板         |
| 3 成型平台及升降機構 | 8 光罩           |
| 4 支撐結構      | 9 重新塗佈及表面平整機構  |
| 5 產品        |                |

# 數位光學式3D列印-基本架構

數位光學式3D列印(DLP, Digi-Optical 3D Printer) :

- 利用UV光源的數位光學投影模組, 將每個單層的切片影像投影於待成形的光敏樹脂槽成形表面上, 經過一定曝光時間將液態樹脂固化為實體物件, 再配合離形機制. 層層堆疊結合為3D立體的固態成形品.

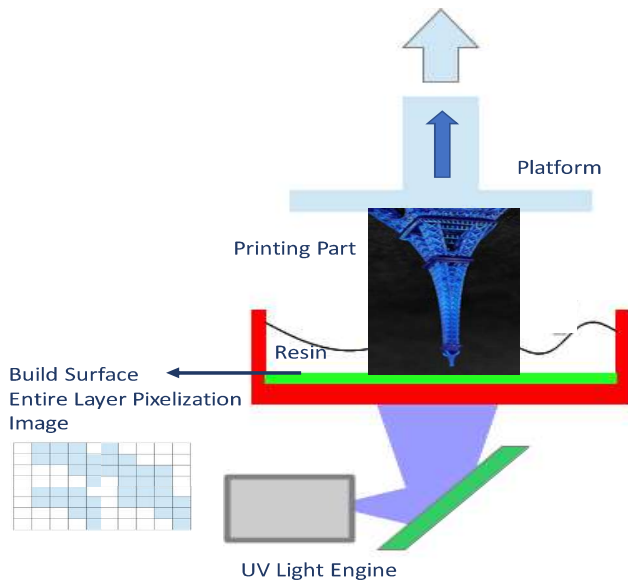

TAIWAN EXCELLENCE GOLD AWARD 2020



2017 Outstanding Photonics Product Award



Miicraft 3D Printers

# 數位光學式(DLP) - 快速列印

快速列印(Speed) :

- 所有3D 列印機中列印速度最快的, 近來高速列印技術發表, 都是基於此技術架構

- 數百萬個數位像素(pixels)整面同時投影曝光
  - 相較於雷射3D列印的單點掃描方式, 先天上在單層的列印時間極短
  - 列印面積越大差異越大
- 固化成形面上的UV功率強度(Power Intensity) 可達 $10\text{mW}/\text{cm}^2$  - 曝光時間短
  - DMD (Digital Micromirror Device) 微反射鏡光閥
  - 高功率UV LED
  - 高效率光學系的設計

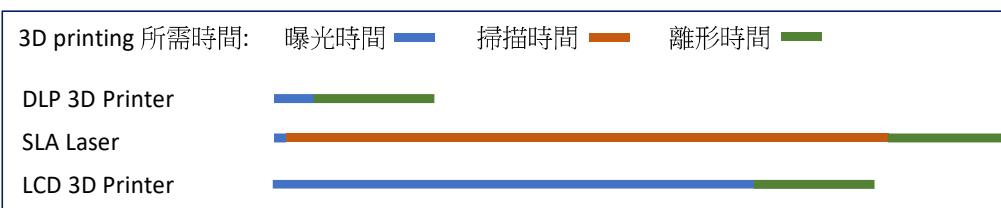

Full Print Dental Model :

- Form2 : <10mm/hr
- LCD : <15mm/hr
- Miicraft : 50mm/hr
- ET : 60mm/hr
- Carbon3D : <80mm/hr

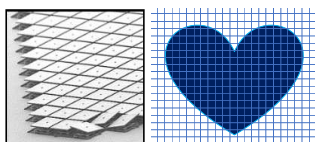

數位光學式(DLP)

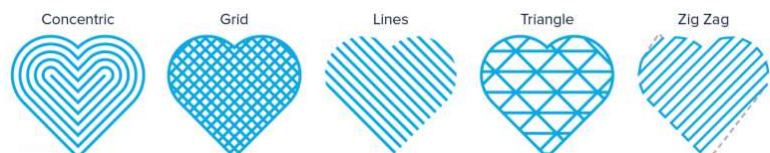

SLA - Single Laser beam

# 數位光學式(DLP) - 穩定度

穩定度(Stability) :

- 單點掃描需要額外兩軸鏡面旋轉, 常常需要週期性的校正雷射光點X/Y平面上的位置

- 每層整面所有像素(pixels)同時曝光, 成形平台(Build Platform) 單軸(Z)上下移動
- 每層畫面都是固定的影像大小, 畫素位置不會改變
- 列印動作穩定, 不需要定期校正

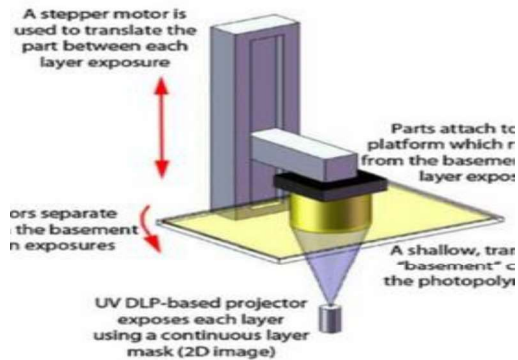

DLP 3D Printer

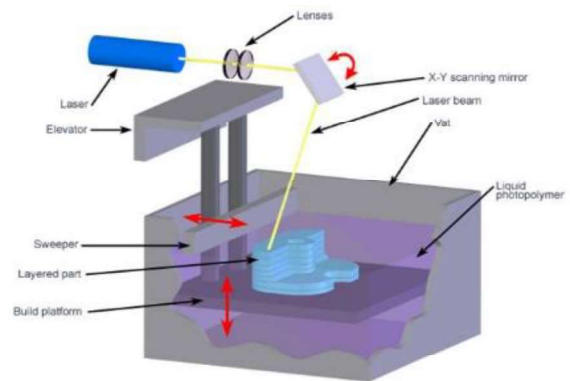

SLA - Single Laser beam

# 數位光學式(DLP) - 精準度

精準度(Accuracy) :

- 大部分商業化的3D 列印機器的像素大小在30um~100um之間

- 藉由數位像素(Pixel)來直接控制待印物件的解析度(Resolution)及精準度
- 達micro等級的3D列印技術
- 膠材光聚合反應的精細度與靈敏度

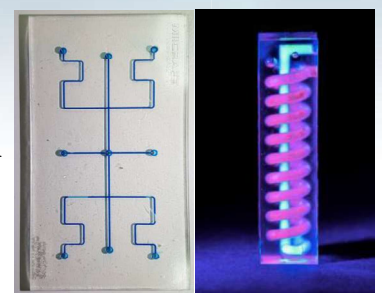

Micraft Printing - Microfluidic

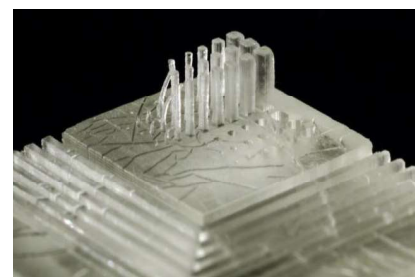
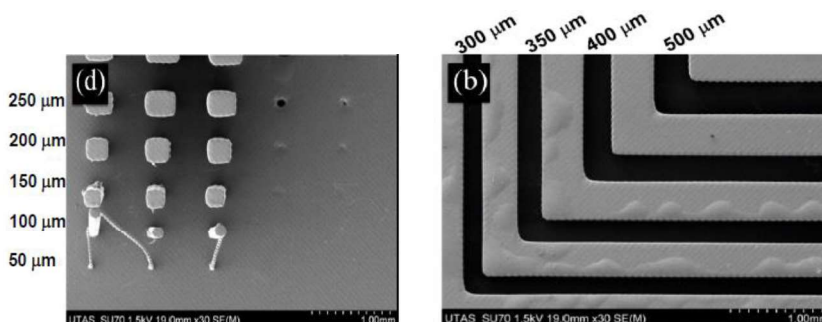

Micraft Printing - Micro Structure

# 數位光學式(DLP) - 壽命&可靠度

使用壽命(Life)&可靠度(Reliability) :

- 先天上結構材料不會吸收UV光(<450nm)而破壞其特性



- 數位光學DLP, DMD灰階, 全數位(0&1)運作傳輸. 液晶旋轉角由電壓高低控制, 屬於類比方式
- 反射鏡面式DMD不會吸收能量, 長時間光照射下不會劣化. 液晶材料及偏光片都會吸收UV光 (<450nm)而破壞特性或是產生烙印
- 長壽命的LED光源(50K hrs)已被常常使用工業等級產品上. Laser需要嚴格溫控, 壽命短(<5K hrs)

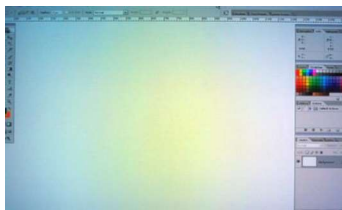
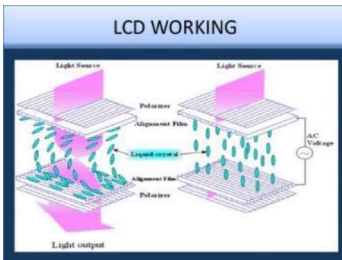

LCD 驅動與劣化

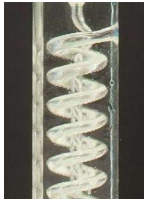

Micraft Printing Parts

3D 列印 UV DLP 光學原理與性能

# UV DLP 投影光機

## UV 光學投影架構：

- 利用精密光學系統，將UV LED光源在光學效率和性能最佳化下，影像投影成像在成形表面上，簡稱為UV DLP光機，或是光機引擎(Optical Engine)。

- DLP (Digital Light Processing) : 驅動電路進行各個像素(pixel)不同時序之On/Off控制, 產生灰階影像, 簡稱為DLP技術
- DMD (Digital Micromirror Device) : 數位光閥
- 光源模組: 收集光源的光強分布
- 照明系統: 光效率, 均勻性等光學性能設計
- 投影鏡頭: 將DMD影像, 成像在成形面
- 散熱系統: 設計系統風流(Air Flow), 控制發熱元件(LED/DMD)的溫度

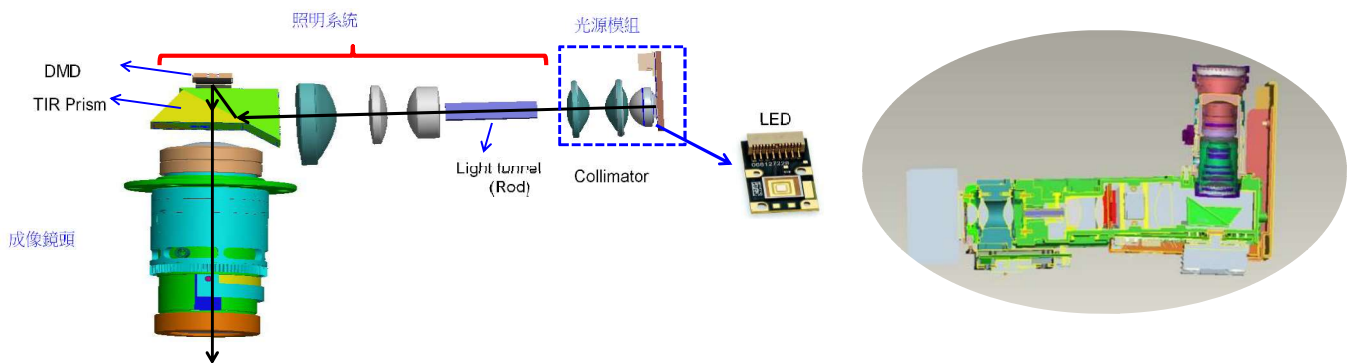

# DMD (Digital Micromirror Device)

## DMD (Digital Micromirror Device) :

- 微機電 (MEMS) 製程裝置, 稱為數位微型反射鏡元件的數位光閥陣列, 以高達每秒上萬次的高速 On/Off 時序切換, 可投射出高品質的影像顯示器

- DLP™ (Digital Light Processing™) 最早由德州儀器 (TI) 在 1987 年發表. 因其純數位轉換, 高可靠度, 高性能等特性, 近年已廣泛應用在投影機, 數位電影, 工業顯示, 半導體曝光設備, 及 3D 列印積層製造等設備

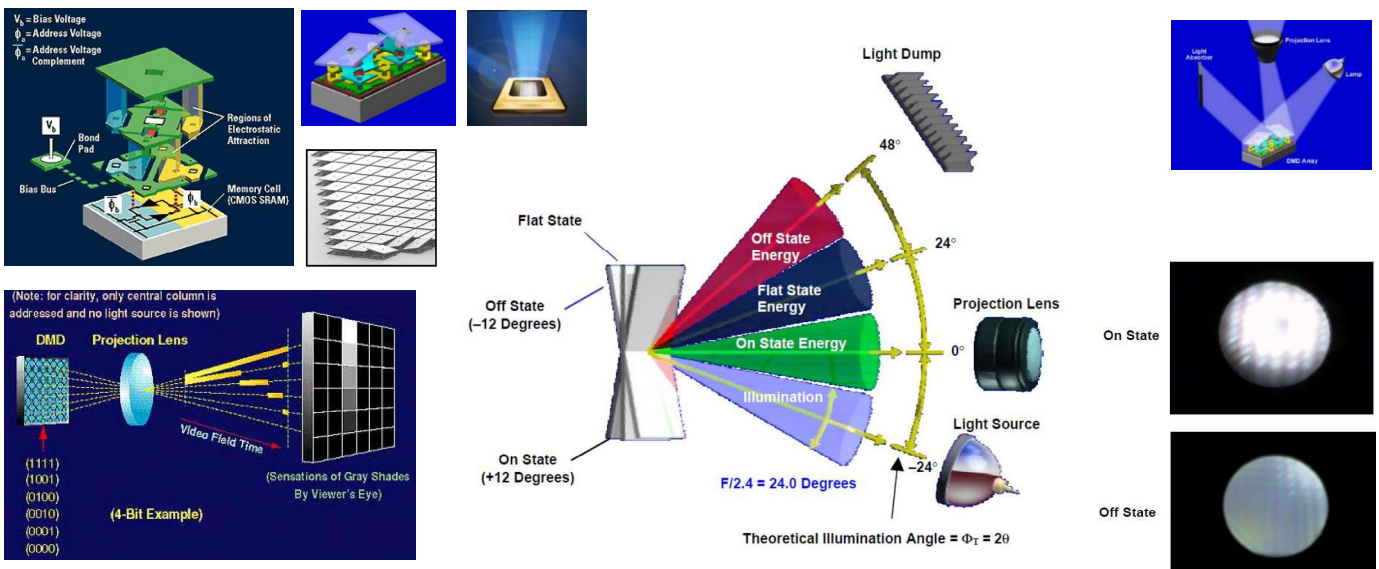

# TIR Prism

TIR Prism全內反射(Total Internal Reflection)稜鏡：

- 利用光由玻璃進入空氣時大角度全反射(Brewster Angle), 小角度折射原理, 將入射與出射DMD的光路錯開
- 將兩個稜鏡夾以及小之空氣間隔(1um to 5um)組合成稜鏡組, 此空氣間隙視DMD Pixel大小而定, Pixel 越小需要越薄的空氣間隔
- 鏡方遠心架構(Telecentric Architecture), 因其入射及出射imager的主光線(Chief Ray)皆為平行, 故具有高均勻度, 低畸變, 高影像品質的優點, 較常應用在工業等級的DLP投影系統

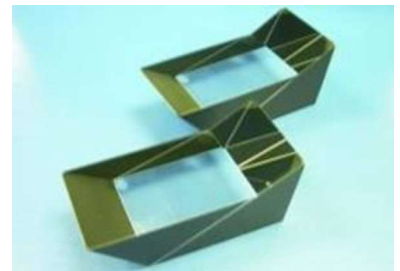
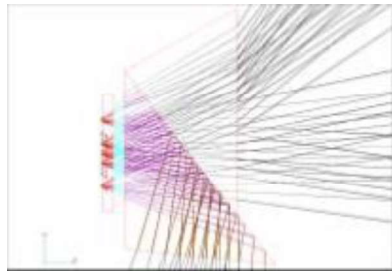
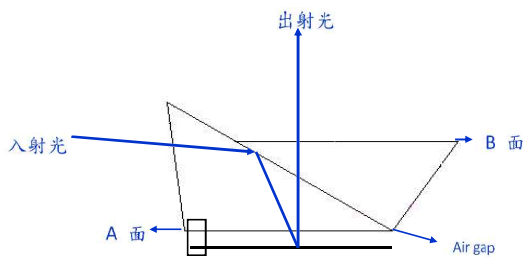

# 積分柱



Integration Rod 積分柱：

- 光均勻化元件, 其作用為讓光強度分布不均勻的光源, 通過此積分柱內時經過數次的光線反彈後, 產生光強分布均勻化的效果
- 積分柱由4片高反射鏡堆疊黏合組成, 為了增加結合剛性, 工業用積分柱常將鏡面切割成階梯型再加以組合, 以符合工業等級應用的可靠度要求

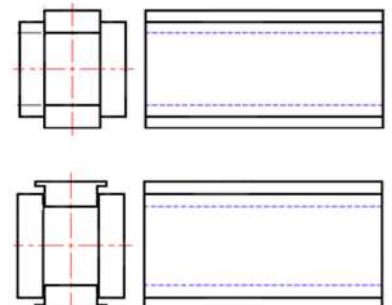
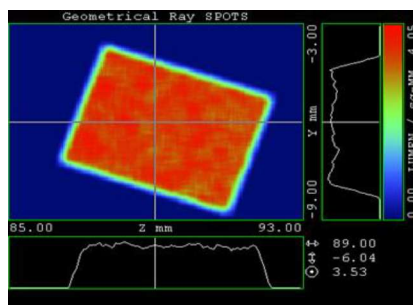
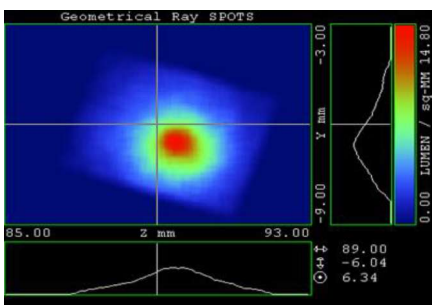
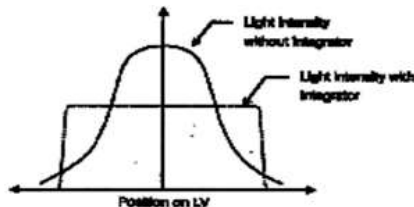
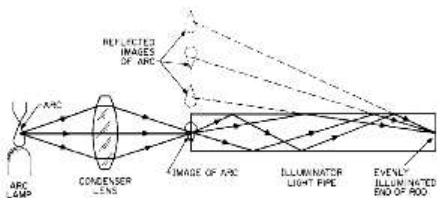

# 成像鏡頭



成像鏡頭：

- 成像投影鏡頭(Projection Lens)由一組鏡片或鏡群，機構鏡筒組合而成，設計時須符合各式光學品質的要求

像差 (Aberration)：為了導正光線經過鏡片所導致的各式像差(Aberration)，需要設計一連串不同材料，不同曲率的鏡片，甚至非球面的組合來互相加以補償平衡以得出最佳的成像鏡頭

- 球差 Spherical - 焦點隨離軸高度而改變，成像點形成對稱式光斑，多鏡片組合或非球面可減少球差
- 慧差 Coma - 焦點隨離軸高度而改變
- 像散 Astigmatism - 光線非對稱地入射透鏡平行和垂直面上焦點不同，子午和弧矢焦線間距愈長像散愈嚴重
- 場曲 Curvature - 不同角度入射，焦距相同成像面是一彎曲面
- 畸變 Distortion - 物體離軸遠近不同有不同放大率

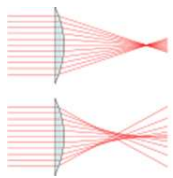
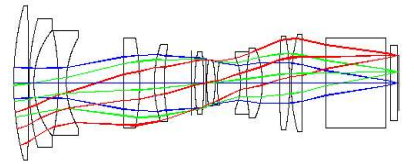

球差

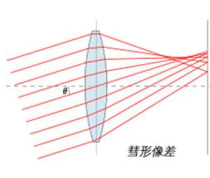

慧差

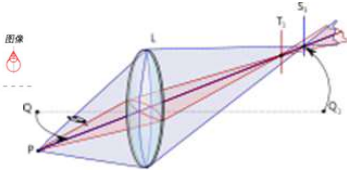

像散

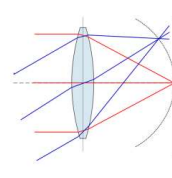

場曲

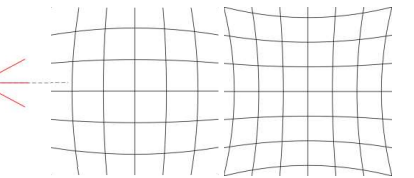

桶狀畸變/枕狀畸變

# 鍍膜

鍍膜(Coating)：

- 增加光學元件穿透率(Transmittance)或是反射率(Reflectivity)，整體光學系的最佳效率及影像特性

- 多層介質薄膜(約500nm內)、空間(Air)及物質(Substrate)間的折射率差異，光的薄膜干涉折射特性來設計不同的光傳輸的特性
- LED光源為近似單一波長，光學系統內的光學元件都可以針對光源波長(Wavelength)的光譜(Spectrum)特性作不同的鍍膜
- 材料的選用需注意是否有短波長吸收的問題，塑膠鏡片(Plastic lens)都會吸收UV光，導致鏡片劣化，工業用產品應盡量避免使用

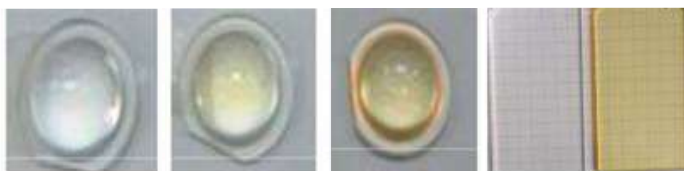
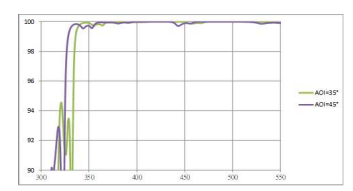
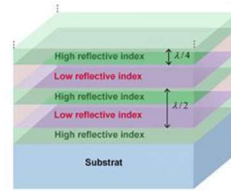
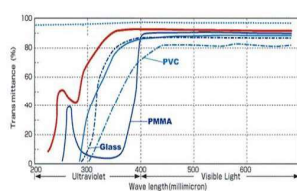
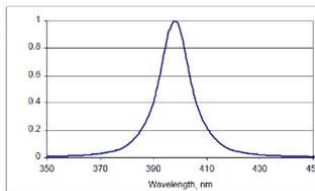

塑膠鏡片劣化



# 光學性能及評價 - 輸出功率

輸出功率 (UV Power, mW) :

- UV光機的輸出功率代表光反應的能力, 光強度越高, 所需的曝光時間越短, 列印速度就越快.
- 一般工業型的UV光機功率輸出皆可達1W( 405nm or 385nm)以上

$$Power\text{-total (mW)} = Intensity[ave] (mW/cm^2) \times Area (cm^2)$$

$$Intensity[ave] (mW/cm^2) = ( I1 + I2 + I3 + \dots + I9 ) / 9$$

- 樹脂可產生光反應的單位面積能量(Energy)

$$Energy = Intensity (mW/cm^2) \times Time (sec)$$

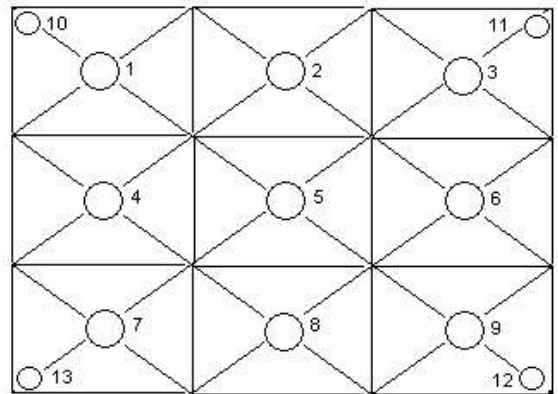
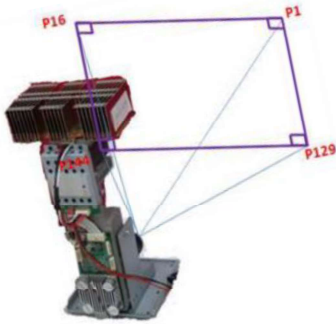

ANSI IT.7-228, 1997

# 光學性能及評價 - 能量均勻度

能量均勻度 (Uniformity) :

- 輔以智慧補償方式, 固化面的影像任一點均勻度亦可達99%
- 近乎100%完美的均勻度, 避免整層曝光時因角落能量低落或是整面能量不均勻導致的列印缺陷.

- ANSI 13點的定義:

$$ANSI\ Uniformity = \frac{\min(10 \sim 13)}{\text{average}(1 \sim 9)}$$

- 畫面分割為144格(16x9):

$$Uniformity (\%) = Intensity[min] / Intensity[max]$$

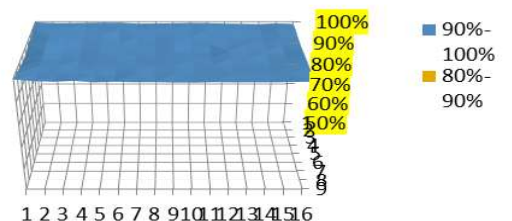
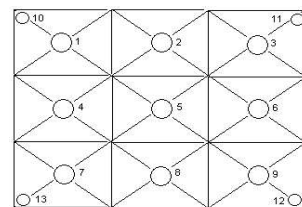

# 光學性能及評價 - 方位度與變形

影像方位度與變形(Orientation & Distortion) :

- 投影畫面需注意影像的幾何大小及方位度(Orientation), 包含成像鏡頭所造成的畸變(Distortion), 以及因機構介面定位偏差所造成的大小及位置偏移
- 影像矯正演算法 (Image Correction Algorithm), 對每個單一pixel全都做校正, 使列印品輸出可以達到um級的精密度 (Pixel Level)

- 光學畸變檢測TV Distortion : 符合工業應用要求的設計通常需要TV distortion < 0.1%

$$TV\ Distortion\ (\%) = ( Dh + Dv ) / 2$$

$$Dh = ( H1 + H2 - 2*H3 ) / 2*H3$$

$$Dv = ( V1 + V2 - 2*V3 ) / 2*V3$$

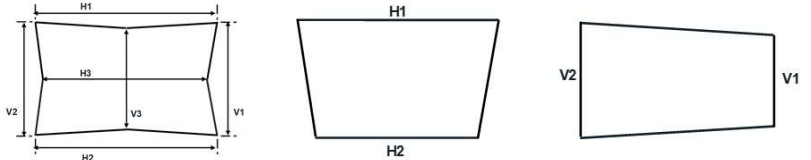

- 影像方位(Orientation) : 包含光學畸變及機構定位誤差造成的偏差(Deviation)

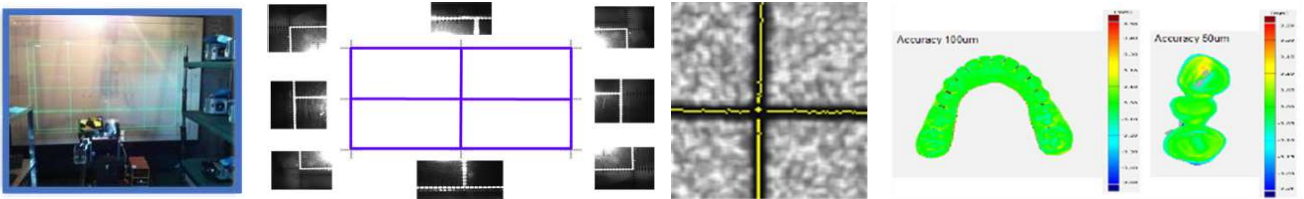

# 光學性能及評價 - 解析度



解析度 (Resolution) :

- 顯示裝置可以顯示的最高有效畫素數量(Pixels), 畫素數量越多, 3D printer的列印就越精細. 常見的解析度為 1920x1080, 3840x2160 等

- 1920\*1080的光機:

$$\text{解析度} = 30\mu\text{m}; \text{面積} = 57.6\text{mm} * 32.4\text{mm}$$

$$\text{解析度} = 100\mu\text{m}; \text{面積} = 192\text{mm} * 108\text{mm}$$

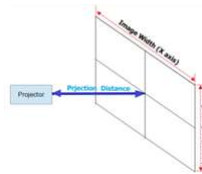
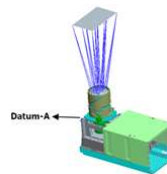

Image Size	2.6inch	4.3inch	4.9inch	8.7inch	unit
Image Width	57.6	96.0	107.5	192.0	mm
Image Height	32.4	54.0	60.5	108.0	mm
Image Diagonal	66.1	110.1	123.4	220.3	mm
Image Pixel Size	30	50	56	100	um
Projection Distance	96.7	174.1	197.4	368.8	mm
Image Resolution	847	508	454	254	ppi

- 更高解析度的4K光機 (3840\*2160 pixels)

$$\text{解析度} = 50\mu\text{m}; \text{面積} = 192\text{mm} * 108\text{mm}$$



DMD pixel size (um)	30	40	50	60	65	70	80	90	100
Datum-A to Screen (mm)	317.4	402.5	487.4	571.4	613.2	654.8	737.4	818.4	898.4
Image width (mm)	115.2	153.6	192	230.4	249.6	268.8	307.2	345.6	384
Image height (mm)	64.8	86.4	108	129.6	140.4	151.2	172.8	194.4	216
Diagonal (inch)	5.2	6.9	8.7	10.4	11.3	12.1	13.9	15.6	17.3

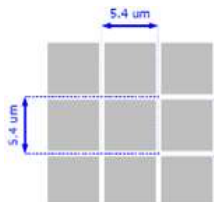

# 光學性能及評價 - 銳利度

銳利度(Sharpness) :

- 鏡頭的成像性能，來源資訊的對比度在影像上呈現出來效果的程度. CTF值越高代表影像越銳利，3D列印品的細節就越清楚

- 空間頻率Line Pair : 每mm中的黑白線對數, 最大可顯示的空間頻率

全頻(Full frequency) =  $1/(2*0.0054) = 92.6 \text{ lp/mm}$  (像素間隔5.4um)

- MTF(Modulation Transfer Function) : 特定正弦波(Sine)空間頻率的對比度比列
- CTF (Contrast Transfer Function) : 特定方波(Square)空間頻率的對比度比列

$$CTF(f) = 100\% * C(f) / C(0)$$

$C(0) = (V_w - V_b) / (V_w + V_b)$  , 低頻的黑白對比度

$C(f) = (V_{max} - V_{min}) / (V_{max} + V_{min})$  , 特定的空間頻率(f, lp/mm) 的黑白對比度

$V_b$  : 低頻中的黑色區域最低亮度值, 此低頻需低至不影響亮度值

$V_w$  : 低頻中的白色區域最高亮度值

$V_{min}$  : 特定的空間頻率(f, lp/mm) 下的最低亮度.

$V_{max}$  : 特定的空間頻率(f, lp/mm) 下的最高亮度值

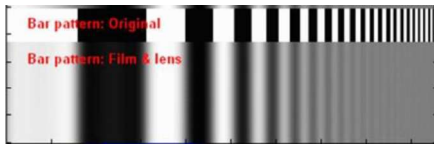
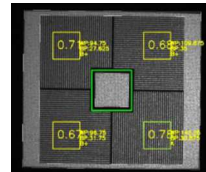
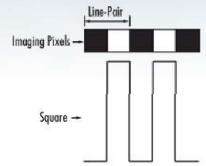

Prime 150  
(Resolution: 55um)

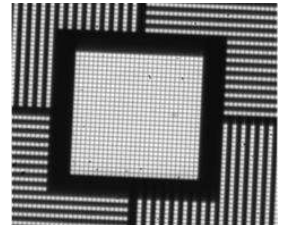

# 解析度提升 - Pixel Shift

Pixel Shift :

- 利用光學制動器(Actuator)光學折射原理, 將畫面在不同的時間序(Time Domain)做半個Pixel的快速位移切換(Pixel Shift, 120Hz), 如此可以造成解析度提高的效果

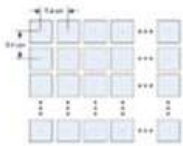

Pixel

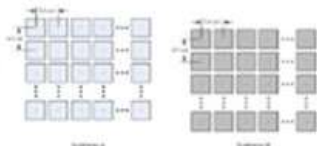

光路透過Actuator使看到的Pixel數量增加

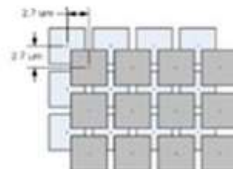

人眼看到的Pixel數量增加·解析度提升

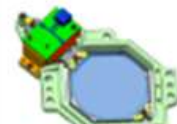
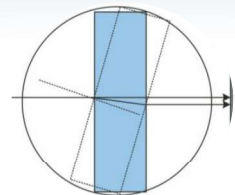

Actuator

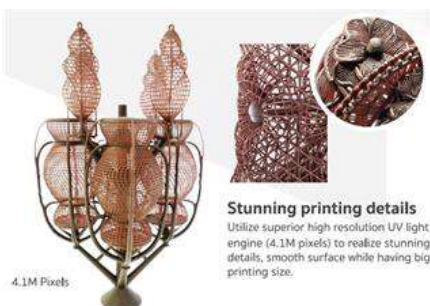

Stunning printing details  
Utilize superior high resolution UV light engine (4.1M pixels) to realize stunning details, smooth surface while having big printing size.



1.4 EM 晶星崗絲鐘  
1.6 EM 晶星崗絲鐘  
1.8 EM 晶星崗絲鐘  
MICRAFT standard  
1.2 EM 晶星崗絲鐘  
1.0 EM 晶星崗絲鐘 50um  
0.8 EM 晶星崗絲鐘

# 散熱的要求

## 散熱的要求 (Thermal Solution) :

- 唯有系統中的致熱元件都在接面溫度 Junction Temperature 限制下操作, 尤其是 LED 及 DMD, 此光機系統才能保證長時間的使用壽命 (Operation Life), 符合工業產品的可靠度要求
- 將各個介質的熱阻值帶入熱流模擬軟體, 使用散熱管或液冷等散熱元件得出良好的散熱設計

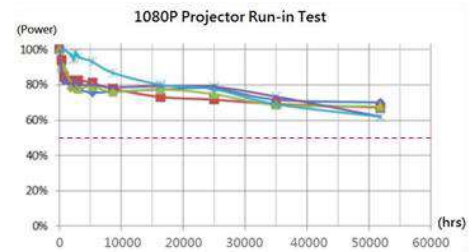
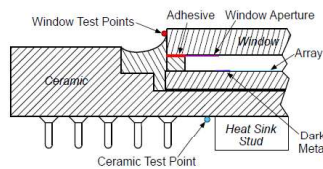
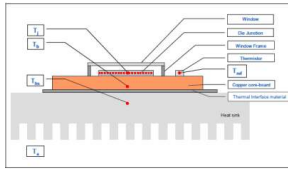
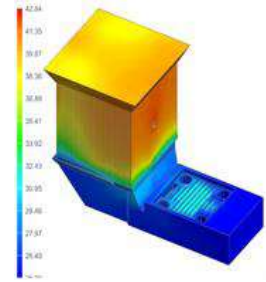
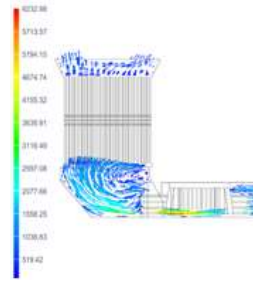
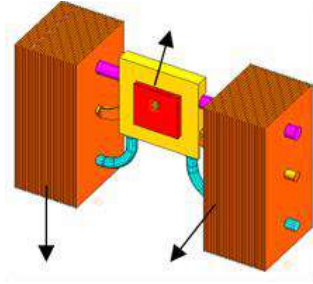

數位光學 DLP 3D 列印機設計

# 上拉式 vs 下沉式

## 上拉式 (Bottom-Up) :

- 光機置於膠槽下方, 成形面位於膠槽底部, 透明玻璃隔離液態膠材, 離形薄膜 (Teflon)讓列印成型工件容易離型 (Peeling), 列印面積150mm以下

- 膠槽不大, 列印時待膠量少
- 小列印面積離型力 (Peeling Force) 不大, 離型模式容易操作, 離型速度快
- 列印面積變大時, 離型就會變得困難

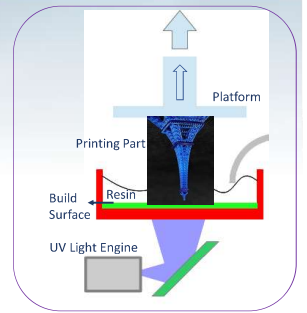

## 下沉式 (Top-Down) :

- 光源置於膠槽上方, 光直接照射液態膠材表面為成形面, 不需要透明介質, 不需要克服離型力, 適合大型的光固化列印設備, 500mm ~ 1000mm (Laser SLA)

- 需要足夠的膠槽容積, 列印時待膠量大
- 液體水平面整平機制 (例如刮刀, Wiper) 控制平面精度, 膠面不平整, 液體波動
- 裝機時常需要現場機台調整及之後的定期校正

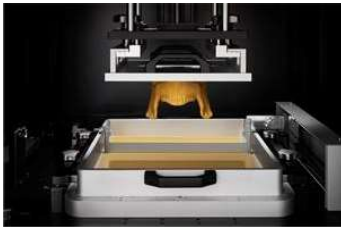
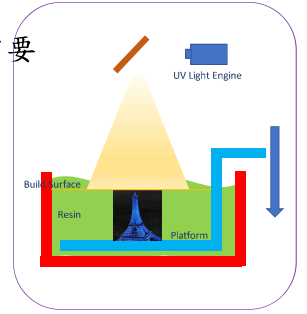

Miicraft 255mmx235mm, 專利離型機制上拉式3D Printer

# 線性滑軌與線性軸承

## 線性滑軌與線性軸承:

- 成形平台藉由馬達驅動上下運動, 搭配線性滑軌或是導桿軸承組合來控制Z軸精度
- 載重負荷, 滑動平行度, 定位精度, 操作壽命, 元件尺寸, 配合公差, 軸承形式, 成本, 供應商選擇
- 執行長時間操作測試來保證機台使用壽命

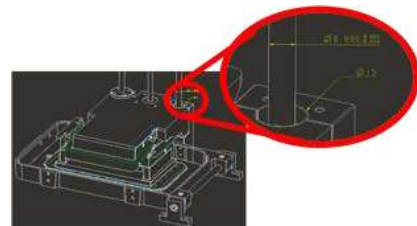
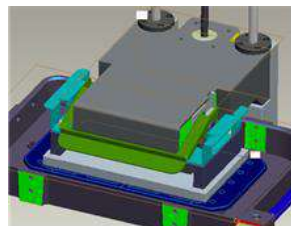
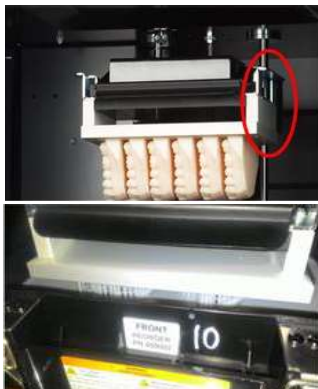

		Another part	bearing
Size	ID	Shaft $\Phi 8 -0.005/-0.014$	$\Phi 8 0/-0.01$
	OD	Cover $\Phi 15 \pm 0.01$	$\Phi 15 0/-0.013$
Life time		The service life vendor provided is about 4,000,000 km by 9.81N force ; 200,000,000 hr. (4,000 km by 98.1N force ; 200,000 hr)	
Running test	Test 8 printer, do lots of times print for each printer	No noise.	Test OK!
		No tilt running smoothly, stably.	Test OK!
		No interference, no part is hurt.	Test OK!
		Running at right position. (data as next page)	Test OK!

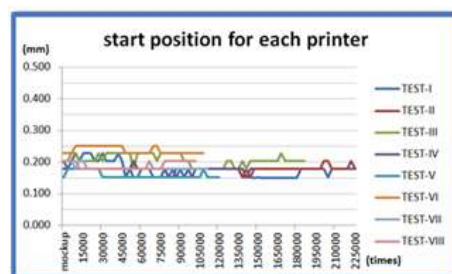

# 離形拉力 (Peeling Force)

離形拉力 (Peeling Force) :

- 離型力與離型介質, 膠材特性, 列印工件的截面積等相關
- 當成形平台上下離型時, 離型壓力峰值發生在平台下降壓在液面時, 當排膠後壓力趨於穩定
- 之後平台上升, 離型力的拉力峰值發生在列印件在離開離型介質的瞬間

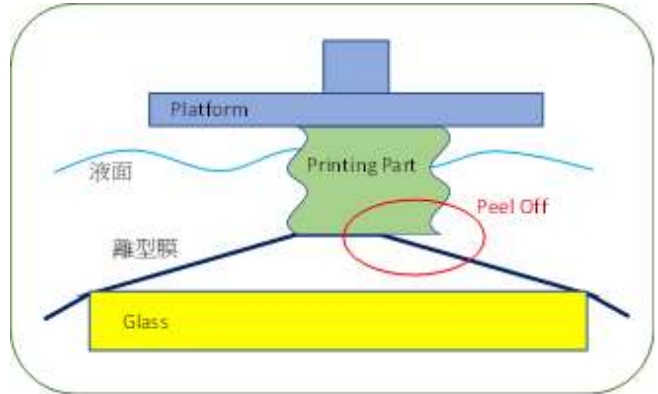
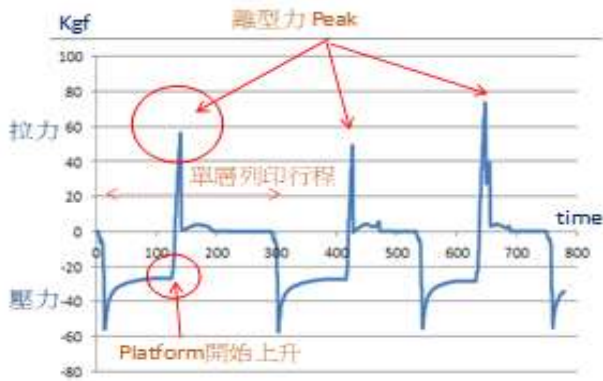

# 接觸角 (Contact Angle)

離型介質的接觸角 (Contact Angle) :

- 列印工件在脫離離型介質時, 此介質相對列印膠材的接觸角, 表面能差異越大, 列印工件離形時的離型力越小, 越容易離形
- 常見的離型介質, 鐵氟龍(Teflon)接觸角量測值約100~120度

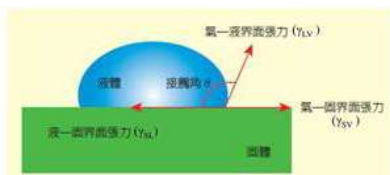

楊氏公式 :  $\gamma_{SV} - \gamma_{SL} = \gamma_{LV} \cos\theta$



水在親水性的表面上散開

水在疏水性的表面上形成水珠

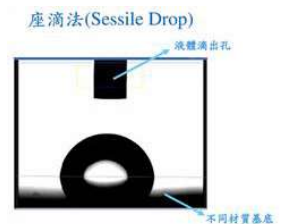

# Miicraft - 主動式輔助離形

## 主動式輔助離形 (Subsidiary Active Peeling):

- 在列印平台的側邊加裝一個輔助驅動馬達, 在工件離形過程中, 除了列印平台的上下運動外, 另輔以傾斜旋轉, 讓整個工件不僅可以加大離形行程, 同時具有兩個離形方向

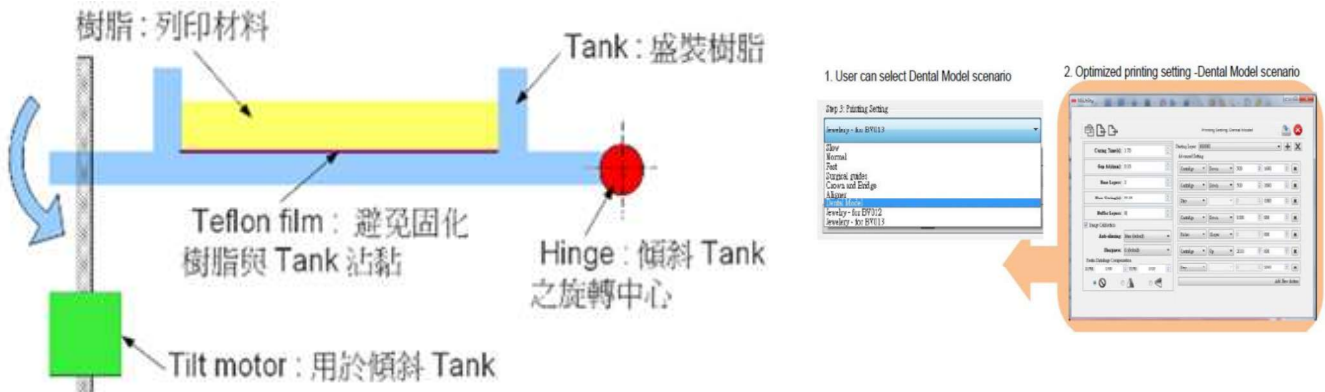

Miicraft 開放所有的運動參數, 使用者可以自行編輯調整. 同時可設定儲存, 適用於不同應用的使用情境(User Scenarios)

# 主動式輔助離形 - Others

## 其他主動離型機制 :

- PDMS (Polydimethylsiloxane, 聚二甲基矽氧烷) which is a type of transparent silicone, FEP (Fluorinated ethylene propylene, 氟化乙烯丙烯共聚物) which is a transparent Teflon
- Subtract : Glass, Acrylic, Silicon,...

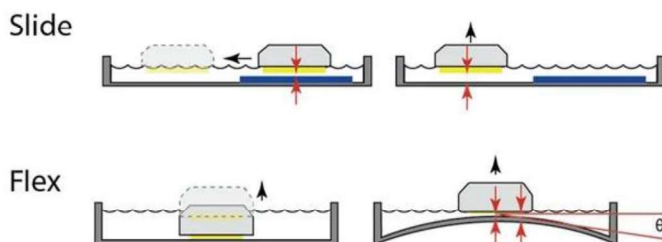
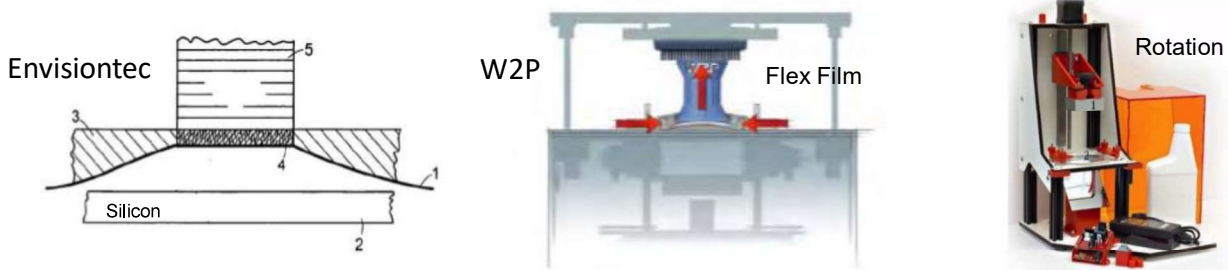

**Change in h**  
Ember, B9

**Peeling**  
Asiga, FSL  
Silicon Subtract

# Miicraft - 氣體動力輔助離形

氣體動力輔助離形 (Aerodynamic Peeling) :

- 利用氣動原理在玻璃上設計一些離形氣孔, 當離形時空氣會進入離形介質與玻璃之間, 加速工件脫離. 也可以主動式注入空氣, 進行主動離形(Active Peeling)

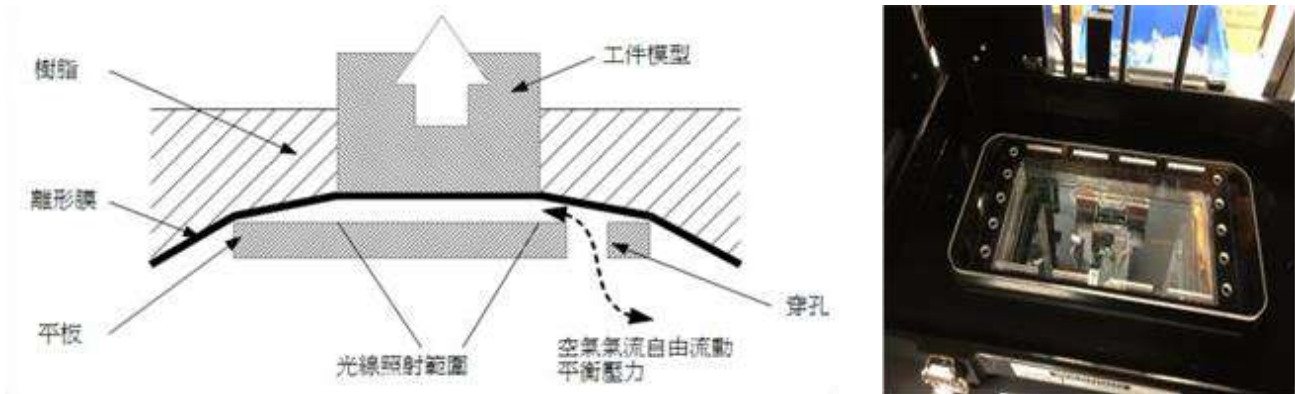

Miicraft專利輔助離形機制, 以應付大面積列印需求, 或是困難離形的特殊應用膠材, 一般性的列印也有加速列印的效果

# Continuous Printing

Continuous Liquid Interface Production (CLIP) :

- The oxygen layer over the window keeps the resin from sticking to the vat and continuous light exposure can be utilized because no 'peel' step is required

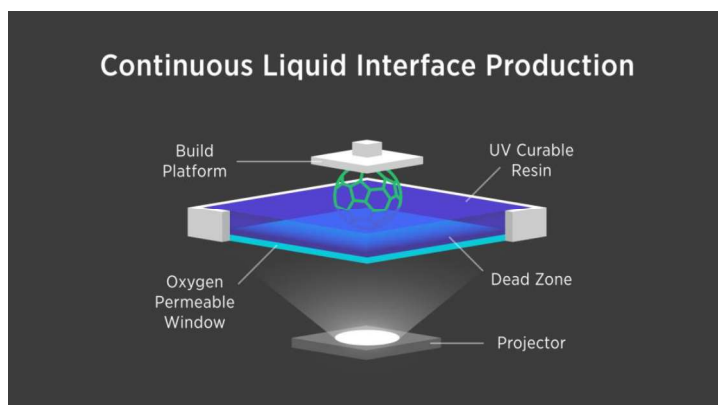

# Miicraft - 影像疊合

## 影像疊合 (Image Stitching) :

- 利用影像疊合的技術擴充列印面積, 實現業界第一個量產的雙光機疊合, 最大列印面積的上拉式 3D Printer

- 有效列印區域 255mm\*235mm, 同時維持高解析度, 兩台DLP光機並排投影 240mm\*135mm\*2
- 精密調整製程, 疊合長邊相鄰部分區域,
- 自行開發的影像融合演算法(Image Stitching Algorithm)

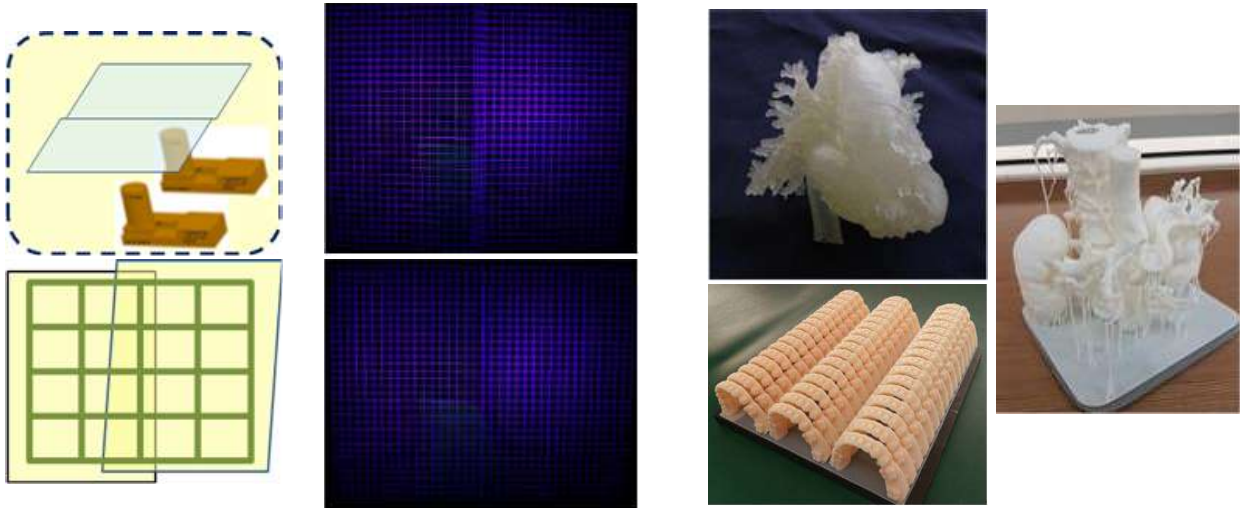

# Miicraft - 影像處理

## 影像處理:

- 三維影像表面處理技術, 讓因層與層疊合所造成的固定層厚的階梯形狀減少, 讓立體曲面變得光滑柔順

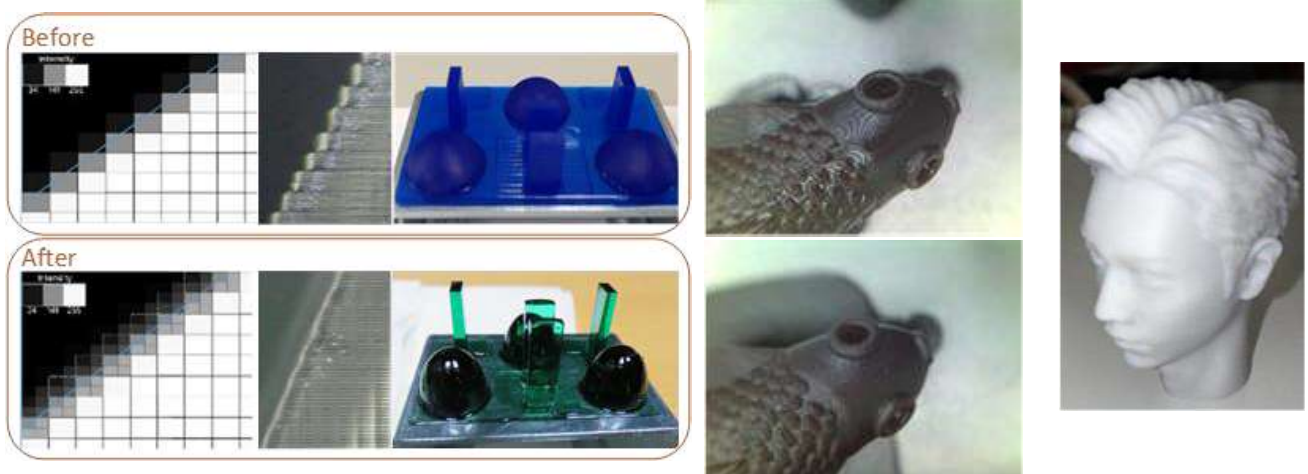

# Miicraft – Programable Peeling Motions

- User Programable Peeling Motions, 擴大各種不同類型膠材, 增加大型列印物件成功率, 降低高黏性膠種離型困難度, 可抑制樹脂內部氣泡, 減少列印品瑕疵
- Variable Peeling Mode per Layer, 每層列印可用不同列印模式
- Adjustable Curing time per layer, 支援每層不同曝光時間
- Multi Exposure by layer, 支援多層重複曝光
- Variable thickness layer to layer, 支援不同切層厚度列印
- Auto Peeling Mode, 智慧型離形模式設定, 可自動分析各切層資訊, 調配不同列印模式

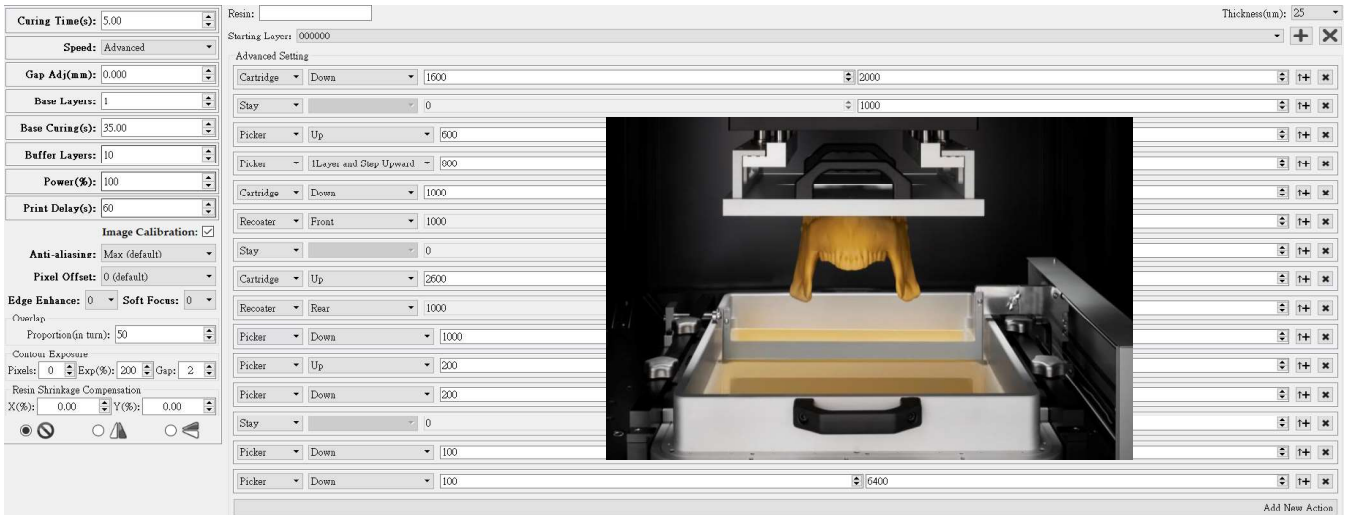

## Miicraft Printer

The most accurate and productive optical 3D printer



### Advance

列印體積: 255x235x200 mm  
 解析度: 125um  
 光學: Dual 1080P

### Profession

列印體積: 250x140x200 mm  
 解析度: 65um  
 光學: 4K

### Prime

列印體積: 150x84.5x120 mm  
 解析度: 55um  
 光學: 2.7K



TAIWAN EXCELLENCE  
 GOLD AWARD 2020

## 數位光學 3D列印機的應用

# 數位光學 3D Printer 應用 - 珠寶

傳統製作方式：仰賴師傅幾十年練就的技藝，越來越難找到傳承

- 耗工：鑄造成金屬後才能通孔(由於蠟模材質過軟，孔型特徵無法事先成形)
- 耗時：師父一天平均約可以雕成2個蠟模(複雜的形狀一個可能就要耗時一週以上)
- 耗費：修整戒指(修台：通孔，開石位，種爪，起花) 損耗約10%-20%的材料。(金，K金，銀，白金，...)



草圖



手工蠟雕



石膏模



脫蠟金屬鑄造



手工修台

數位光學式3D Printer：高解析度，高精密度

- 細節特徵，微小側孔直接列印，不需人工通孔，降低繁複花式戒指製作難度，降低材料損耗
- Miicraft Profession 250mm：3小時可一次同時列印40個戒指環，抵上20個師父的產量
- 列印範圍中間或角落區域，每個都完美呈現所有細節
- 可以透過3D繪圖或3D列印模型直接跟客人確認，避免客戶想像的造型及成品之間的落差
- 機台價格親民，單次列印的成本低，所有的貴金屬材料皆可製作產出

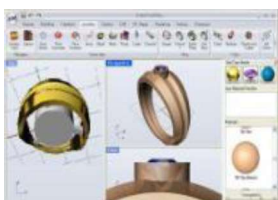

3D Design



3D Printing



Casting



成品

# Miicraft 珠寶列印



# 數位光學 3D Printer 應用 – 牙科

齒科(Dental)：

- 數位牙科(Digital Dentistry)的進展, 光學式3D列印可製作所有牙醫師, 牙技所(Dental Lab)的應用

- Miicraft Advance 255 三個小時內一次列印約50個齒模
- 不需要技工, 牙醫診所/牙技所, 均可設置機台操作
- 醫師和患者, 可以在第一時間同時同步確認, 降低牙技師, 醫師, 患者間的製作誤差
- 齒模, 臨時假牙, 手術導版, 矯正器... 等等所有齒科的應用

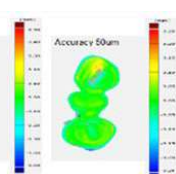
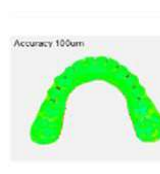

# Miicraft Dental

Miicraft Printer設定為開放系統,可以列印各式Dental應用的膠材,包含FDA, CE, TFDA, 等各國認證過的生物相容醫材類材料

Prosthetics Model			OrthoModel			Guide			Cast					
BV005A Dental model caramel		keystone KeyOrthoModel caramel		BV005A Dental model caramel		keystone KeyGuide clear FDA Class I		BV013A Cast HD brown						
BV006 Dental model white		DETA X Freeprint model ivory, gray, sand, caramel		BV006 Dental model white		DETA X Freeprint ortho clear CE Class I		BV014 Cast red						
BV008 Dental model gray		Dreve FotoDent model caramel		Eternal Dental model snow white		Dreve FotoDent drill guide clear CE Class I		keystone KeyCast transparent purple						
Eternal Dental model snow white		Dentona Optiprint model clear		keystone KeyOrthoModel gray		Dentona Optiprint splint clear CE in processing		DETA X Freeprint cast red						
Enlighten PP model purple		Dentona Optiprint match ivory		DEIA X Freeprint model T light blue		Enlighten DD guide clear TFDA Class I		Dentona Optiprint cast red						
3DM DENT brown, ivory, gray		NextDent Model 2.0 Peach, White and Grey		NextDent Dental Ortho Beige		NextDent orange CE Class I		NextDent Cast purple						
Temporary			Denture			Retainer			Tray			Gingiva		
DETA X Freeprint temp A1, A2, A3 CE Class IIA		DETA X Freeprint denture CE in processing		keystone KeySplint Hard clear FDA Class II		DETA X Freeprint tray green CE Class IIA		keystone KeyMask pink						
Enlighten AA TEMP A2 Plan to apply		Enlighten BB base Plan to apply		keystone KeySplintSoft clear FDA Class II		Enlighten CC tray blue TFDA Class I		DETA X Freeprint gingiva gingiva						
MMtech Temporary A3 Plan to apply		Dreve FotoDent denture CE class IIA		DETA X Freeprint splint clear CE Class IIA		Dentona Optiprint try blue CE in processing		Dentona Optiprint gingiva pink						
Veltz DT-1 A2 KFDA		NextDent Denture 3D+ Dark Pink, Light Pink, Opaque Pink, Red Pink, and Translucent Pink CE Class IIA		DETA X Freeprint ortho clear CE Class IIA		Dreve FotoDent tray green CE class I		Dreve FotoDent gingiva pink						
NextDent C&B MFH BL, NL, NLS, N2, N2.5, N3 and T1 CE Class IIA				Dentona Optiprint splint clear CE in processing		NextDent Tray in T10, T11, T12 CE Class I		NextDent Gingiva Mask pink						

## 數位光學 3D Printer 應用 - 醫療

醫學上的應用非常適合3D列印的製造工法,尤其是生物相容性可列印醫材的進展突飛猛進,可以預期10年內,會有一半的醫療產品是由積層製造生產而來。

- 大型軟性材質的列印,可以協助醫院醫師在醫療輔助,醫療設計驗證,術前預操作等
- 助聽器(Hear Aid), 牙齒矯正器(Aligner),... 都是經由數位光學3D Printer製程生產而成。
- 國內外醫學研究中心,大學研究機構合作,利用光學式3D列印高精密及材料多元的特性,開發生物相容可再生的微結構,類血管等

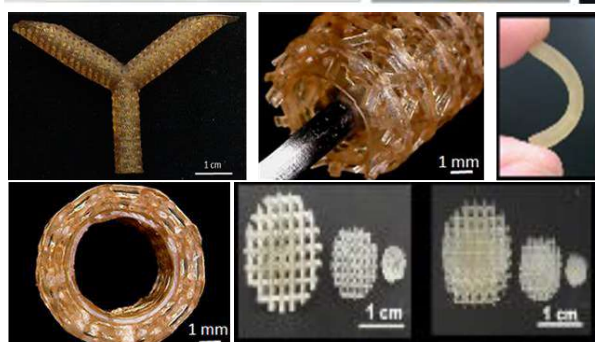

materials

MDPI

Article  
3D Printing of Cytocompatible Water-Based Light-Cured Polyurethane with Hyaluronic Acid for Cartilage Tissue Engineering Applications

Ming-You Shie <sup>1,2</sup>, Wen-Ching Chang <sup>1</sup>, Li-Ju Wei <sup>1</sup>, Yu-Hsin Huang <sup>1</sup>, Chien-Han Chen <sup>1</sup>, Cheng-Ting Shih <sup>1</sup>, Yi-Wen Chen <sup>1,3\*</sup> and Yu-Fang Shen <sup>1,3\*</sup>

# Miicraft – 微流道



應用化學上的微流道(Microfluidic)應用, 可以用於液體的萃取, 分流, 混合等等, 是最早的應用之一

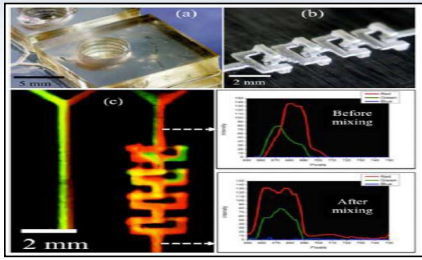

Mixing 混合

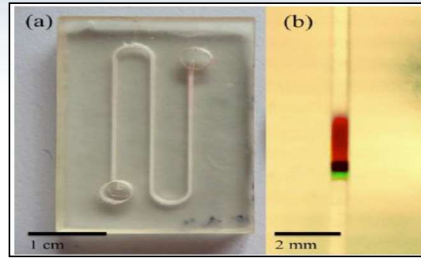

Isotachopheresis(ITP) 等速電泳

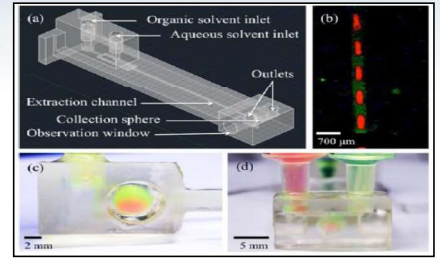

Extraction 萃取

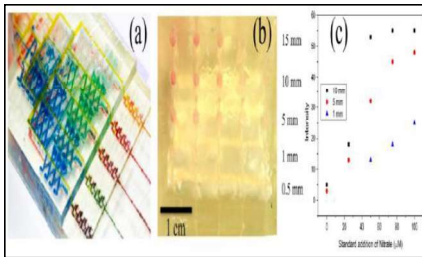

Analysis of Nitrate 硝酸鹽

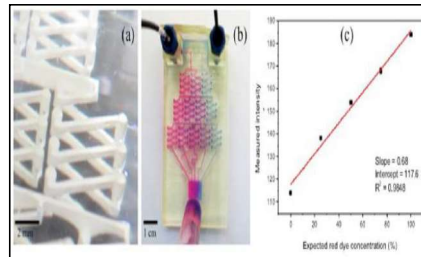

Gradient 梯度分布

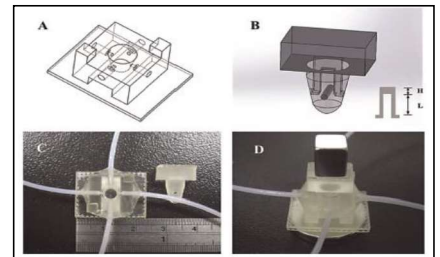

Load/Inject Valves 活門

Cost-Effective Three-Dimensional Printing of Visibly Transparent Microchips within Minutes [Aliaa I. Shalhan](#) †‡, [Petr Smejkal](#) †, [Monika Corban](#) ‡, [Rosanne M. Guijt](#) ‡, and [Michael C. Breadmore](#) \* † <http://pubs.acs.org/doi/abs/10.1021/ac4041857>

Novel instrument for automated pKa determination by Internal Standard Capillary Electrophoresis [Joan Marc Cabot](#), [Elisabet Fuguet](#), [Martí Roses](#), [Petr Smejkal](#), and [Michael C. Breadmore](#) <http://pubs.acs.org/doi/abs/10.1021/acs.analchem.5b00845>

Three-dimensional printed sample load/inject valves enabling online monitoring of extracellular calcium and zinc ions in living rat brains [Cheng-Kuan Su](#), [Sheng-Chieh Hsia](#), [Yuh-Chang Sun](#) <http://www.sciencedirect.com/science/article/pii/S0003267014007806>

# 數位光學 3D Printer 應用 – 工業應用

功能件(Functional Parts) :

- 工業用膠材涵蓋範圍非常廣泛, 依列印成品的硬度來分類, 可以看到從軟性的類橡膠(Rubber Like), 矽基底(Silicon)材料, 到硬度高到可當作剪刀, 假牙等
- Miicraft不願意妥協材質特性, 運用機台獨特的列印機制, 克服難以列印離形的膠材

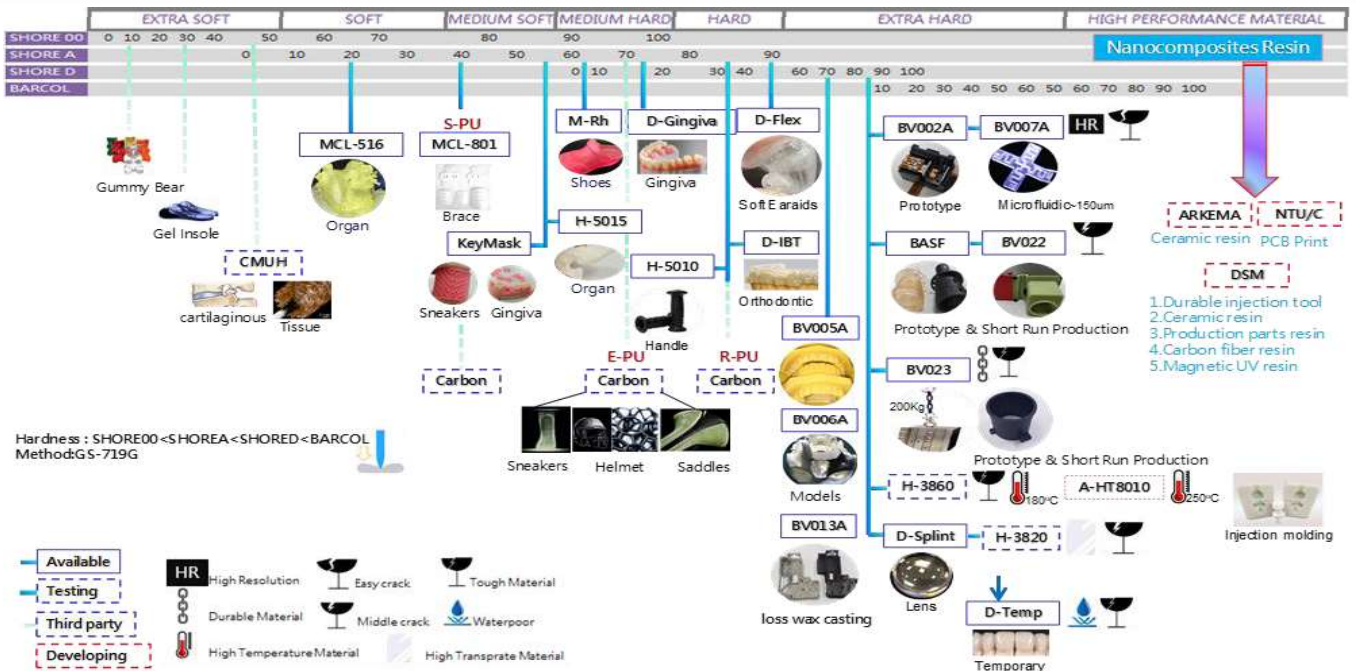

# Miicraft – 類工程塑膠

類工程塑膠：

- 各式各樣的工業產品應用，如PP-like, ABS-Like, Rubber-Like等，不同的拉力強度及彈性特性分佈
- 吊掛200Kg的絞鍊，或具彈性的卡扣，透明的光學件等，均已商品化

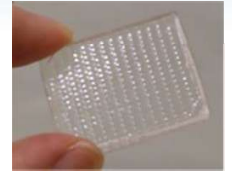
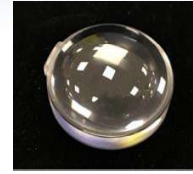

# Miicraft – Functional Parts

所有這些材料，都可以用同一台數位光學式的3D列印機列印出來

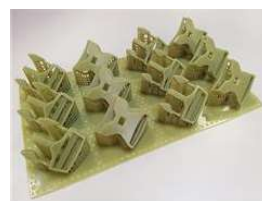
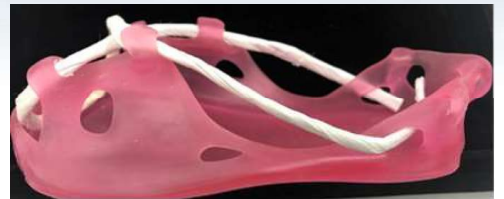

## 未來展望

# 非塑膠類的列印材料

非塑膠類的材料發展：

- 法藍瓷, Lithoz, .. 推出陶瓷(Ceramic)的3D列印設備, 由於陶瓷漿料非常黏稠不易流動, 成形後收縮率很高, 需要不同技術來克服
- 也可以思考是否可以延伸至金屬材料, 實現光固化金屬列印



Miicraft



Franz

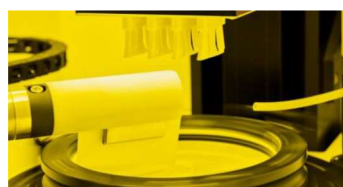

Lithoz Ceramic 3D Printing

# 複合材料

複數或複合材料的列印：

- Miicraft 與工研院合作, 將液態膠槽擴充為三個, 每層列印時, 幫浦輪流將三種不同材料的膠材打入列印槽中曝光顯像, 形成三種不同性質材料立體成形的3D物件
- 可以是軟硬複合的醫療輔具, 面罩, 也可以是彩色的工件, 期待後續有不同的技術發展, 實現複數複合材料光固化列印的目標

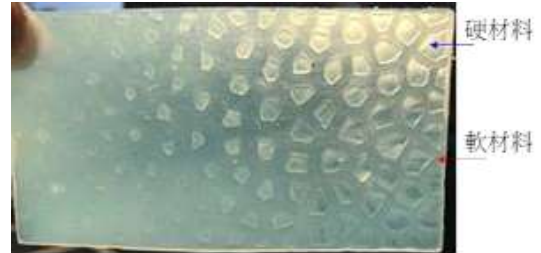
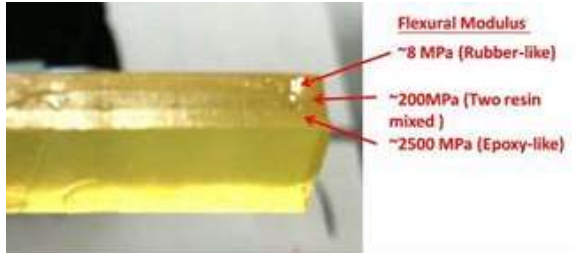

## In Near Future

數位光學光固化積層製造從消費性電子產品走向工業應用, 從文創走向醫療, 從觀賞模型走向功能件製造

- 50年內會有一半的零件生產產值, 會由傳統的減法製程, 模具射出量產製程, 轉換為積層製造加法製程
- 台灣的3D列印持續投入耕耘, 結合台灣不同產業的強項, 運用自身的優勢, 隨著積層製造起飛的趨勢, 在世界上佔有一席之地
- 2020年的冠狀病毒, 導致全世界都缺乏醫療呼吸及口罩, 3D 列印為全世界人類對抗病毒貢獻心力



Soft Mask



Mask

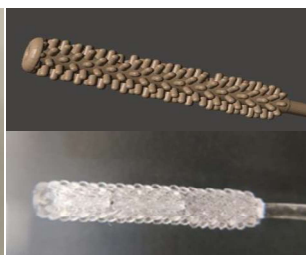

Nasal Swabs



Ventilator Valve



Eye Protection

